

Simple  friendly

 **Kawasaki**

**Kawasaki Robot  
RS03N (A/B00\*)  
RA03N (A/B00\*)**

**Installation and  
Connection Manual**

**Robot**

**Kawasaki Heavy Industries, Ltd.**

90202-1043DEA

## PREFACE

This manual describes the installation and connection instructions for the Kawasaki Robot RS03N (A/B00\*)/RA03N (A/B00\*).

Read and understand the contents of this manual and the safety manual thoroughly, and strictly observe all rules for safety before proceeding with any operation.

This manual only describes the installation and connection of the robot arm. Refer to the “Installation and Connection Manual – Controller” for information on the controller.

Never proceed with any operation until you understand the contents of this manual completely.

Kawasaki is not responsible for any accidents and/or damages resulting from operations/maintenance based on only a limited reading or limited understanding of some parts of this manual.

— This manual describes the following robot model. —

RS03N (A00\*) ... Standard specifications (Floor/ceiling mount)  
RS03N (B00\*) ... Standard specifications (Wall mount)  
RA03N (A00\*) ... Arc weld specifications (Floor/ceiling mount)  
RA03N (B00\*) ... Arc weld specifications (Ceiling mount)

- 
1. This manual does not constitute a guarantee of the systems in which the robot is utilized. Accordingly, Kawasaki is not responsible for any accidents, damages, and/or problems relating to industrial property rights as a result of using the system.
  2. It is recommended that all personnel assigned for activation of operation, teaching, maintenance or inspection of the robot attend the necessary education/training course(s) prepared by Kawasaki, before assuming their responsibilities.
  3. Kawasaki reserves the right to change, revise, or update this manual without prior notice.
  4. This manual may not, in whole or in part, be reprinted or copied without the prior written consent of Kawasaki.
  5. Store this manual with care and keep it available for use at any time. If the robot is reinstalled or moved to a different site or sold off to a different user, attach this manual to the robot without fail. In the event the manual is lost or damaged severely, contact Kawasaki.

## SYMBOLS

The items that require special attention in this manual are designated with the following symbols.

Ensure proper and safe operation of the robot and prevent physical injury or property damages by complying with the safety matters given in the boxes with these symbols.

 **DANGER**

**Failure to comply with indicated matters can result in imminent injury or death.**

 **WARNING**

**Failure to comply with indicated matters may possibly lead to injury or death.**

 **CAUTION**

**Failure to comply with indicated matters may lead to physical injury and/or mechanical damage.**

**[ NOTE ]**

Denotes precautions regarding robot specification, handling, teaching, operation, and maintenance.

 **WARNING**

- 1. The accuracy and effectiveness of the diagrams, procedures, and detail explanations given in this manual cannot be confirmed with absolute certainty. Accordingly, it is necessary to give one's fullest attention when using this manual to perform any work.**
- 2. Safety related contents described in this manual apply to each individual work and not to all robot work. In order to perform every work in safety, read and fully understand the safety manual, all pertinent laws, regulations and related materials as well as all the safety explanations described in each chapter, and prepare safety measures suitable for actual work.**

## CONTENTS

Preface.....	1
Symbols.....	2
1.0 Precautions.....	4
1.1 Cautions to be Taken during Transportation .....	4
1.2 Installation Environment of Robot Arm .....	6
2.0 Motion Range and Specification.....	7
2.1 Setting the Dimensions of the Safety Fence based on Max. Motion Range .....	7
2.2 Robot Motion and Specification.....	8
3.0 Transport Method.....	10
4.0 Installation Method .....	11
4.1 Installing Robot Arm .....	11
5.0 Installation of Tools .....	13
5.1 Dimensions of Wrist End (Flange Face) .....	13
5.2 Setting the Load Mass.....	14
6.0 Connection of Air System.....	16
6.1 RS03N (A/B00*) .....	16
6.1.1 Air Piping Diagram.....	16
6.1.2 Connection to the Tool from Air Outlet .....	17
6.1.3 Air Inlet to the Robot Arm.....	17
7.0 Precautions at Repeat Operation (RS03N/RA03N (A/B00*)) .....	18

## 1.0 PRECAUTIONS

### 1.1 CAUTIONS TO BE TAKEN DURING TRANSPORTATION

When transporting the Kawasaki Robot to its installation site, strictly observe the following cautions.



#### WARNING

1. When the robot arm is to be transported by using a crane or forklift, never support the robot arm manually.
2. During transportation, never climb on the robot arm or stay under the hoisted robot arm.
3. Prior to installation, turn OFF control power up to the main power source. Display signs indicating clearly “Inspection and Maintenance in Progress”, and lockout/tagout the main power switch to prevent personnel from accidentally turning ON the power.
4. Prior to driving robot, ensure safety by first confirming no abnormality is observed in installing condition, etc., and then turn ON motor power to set robot to the desired posture. Be careful to not be caught by/between any moving parts due to careless approach to robot and peripheral equipment. After setting robot arm to the specified pose, turn OFF control power up to the main power source again as mentioned above. Display signs indicating clearly “Inspection and Maintenance in Progress”, and lockout/tagout the main power switch before starting inspection and maintenance.
5. Warning labels are affixed to the arm to identify areas with possibility of electric shock, high temperature or pinching/crushing, so check these areas beforehand. See the following page for the warning labels and their positions.



#### CAUTION

1. Since the robot body unit is composed of precision parts, be careful not to apply excessive shocks during transportation.
2. Prior to installation, remove all obstacles so the installation is carried out smoothly and safely. Clear a passage to the installation area for transportation of the robot arm using a crane or forklift.
3. During transportation and storage,
  - (1) Keep the ambient temperature within the range of  $-10^{\circ}\text{C} \sim 60^{\circ}\text{C}$ ,
  - (2) Keep the relative humidity within the range of 35 % ~ 85 % RH without dew condensation,
  - (3) Keep free from excessively strong vibration or shocks.

Warning labels

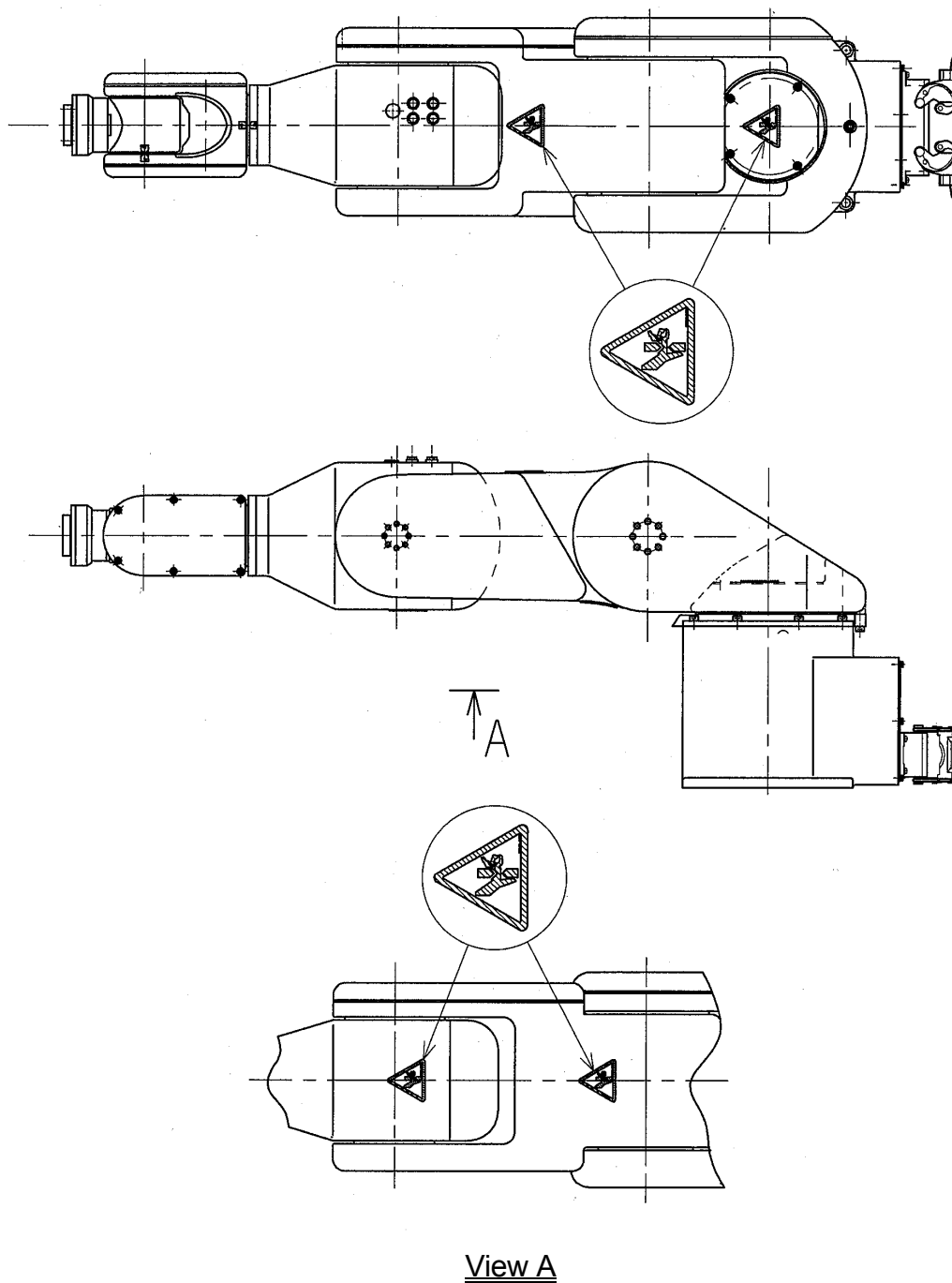

 : Warning label for pinching point

## 1.2 INSTALLATION ENVIRONMENT OF ROBOT ARM

When installing the robot, set it up in a site where the following ambient conditions are satisfied.

1. When installing on the floor or on the ceiling, secure the level within  $\pm 5^\circ$ .
2. Ensure the floor or stand provides sufficient rigidity.
3. Secure flatness so force is not applied excessively on any installation components. If flatness cannot be achieved, compensate using liners.
4. Ambient temperature during operation should be within  $0^\circ\text{C} \sim 45^\circ\text{C}$ . (Deviation or overload error may occur due to high viscosity of grease/oil when starting operation at low temperatures. In this case, warm-up robot at low speed before regular operation.)
5. Relative humidity should be 35 % ~ 85 % RH; without condensation.
6. Secure an area with very little exposure to dust, smoke, oil and water.
7. Secure an area free from flammable or corrosive liquid or gas. (Use a robot arm with explosion-proof spec. if environment is flammable.)
8. Secure an area not affected by excessively large vibrations. (0.5G or less)
9. Secure an area with minimal electrical noise.
10. Secure a place that is spacious enough for the motion range of the robot.
11. Set up a safety fence around the robot arm, providing adequate space for the maximum motion range of the robot arm and without causing any interference to tool installed on the robot arm.
12. Provide as few entrances as possible (if possible only one) on the safety fence with a safety plug built into the door. \*

**NOTE\*** For safety fence specifications, observe the requirements of JIS B8433 or equivalent.

## 2.0 MOTION RANGE AND SPECIFICATION

### 2.1 SETTING THE DIMENSIONS OF THE SAFETY FENCE BASED ON MAX. MOTION RANGE

The motion range of the robot is the area reachable by point P.

$L_0$ : Robot motion range (Distance from A to point P.) (Refer to 2.2)

$L_1$ : Sum length of wrist flange, tool and workpiece

$L_2$ : Clearance for safety

Refer to the figure below and ensure safety fence dimensions are larger than the sum of  $L_0+L_1+L_2$ .

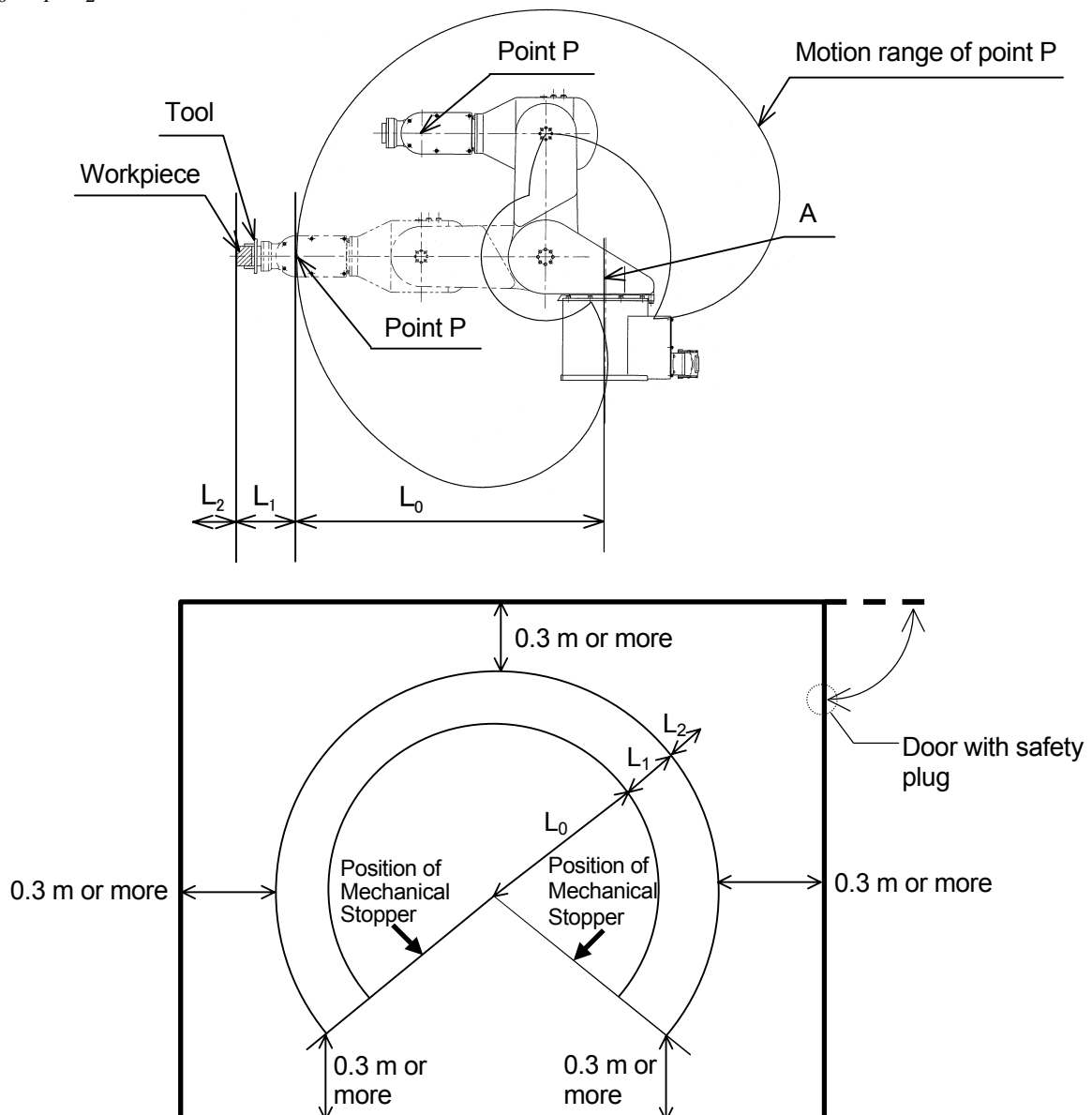





RS03N (B00\*)/ RA03N (B00\*)

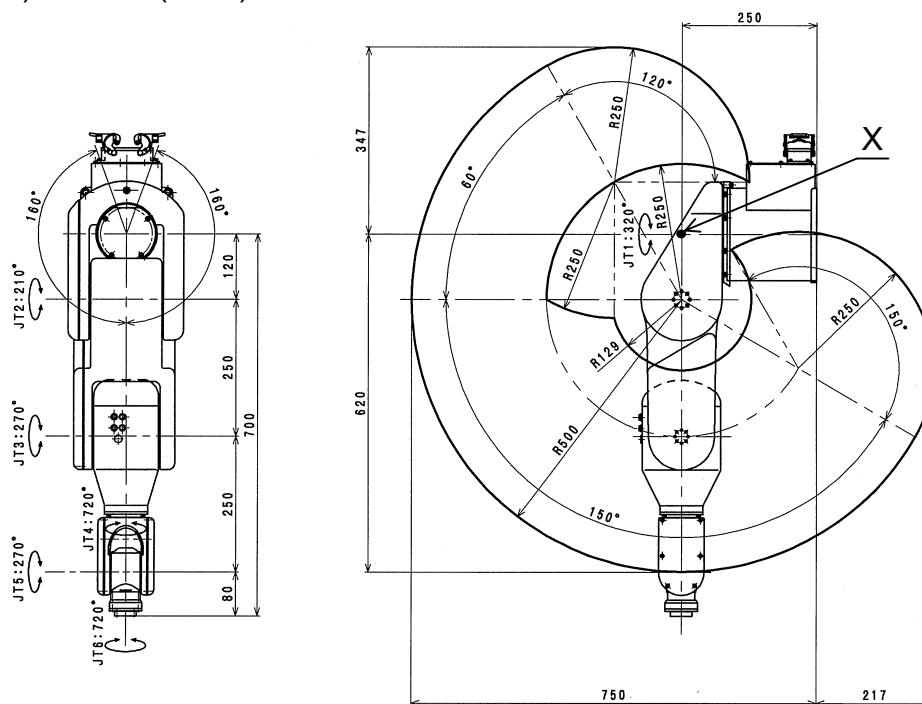

Type	Articulated robot		
Degree of Freedom	6		
Motion Range and Maximum Speed	JT	Motion range	Max. speed
	JT1	-160° ~ +160°	150 °/s
	JT2	-60° ~ +150°	250 °/s
	JT3	-150° ~ +120°	225 °/s
	JT4	-360° ~ +360°	540 °/s
	JT5	-135° ~ +135°	225 °/s
	JT6	-360° ~ +360°	540 °/s
Max. Payload	3 kg		
Wrist Load Capacity	JT	Load torque	Load moment of inertia
	4	5.8 N·m	0.12 kg·m <sup>2</sup>
	5	5.8 N·m	0.12 kg·m <sup>2</sup>
6	2.9 N·m	0.03 kg·m <sup>2</sup>	
Repeatability	± 0.05 mm		
Driving Motor	Synchronous brushless AC servo motor		
Mass	Approx. 20 kg		
Settable Mechanical Stopper	JT1 only (45° pitch)		
Base Origin	Point X in figure above		
Acoustic Noise	< 70 db (A)*		

**NOTE\*** Measurement conditions  
 · robot installed on plate rigidly fixed to floor  
 · measuring point:  
 1300 mm away from JT1 center  
 (The noise level depends on the conditions.)

### 3.0 TRANSPORT METHOD

Robot arm is packed as shown below at time of factory shipment.

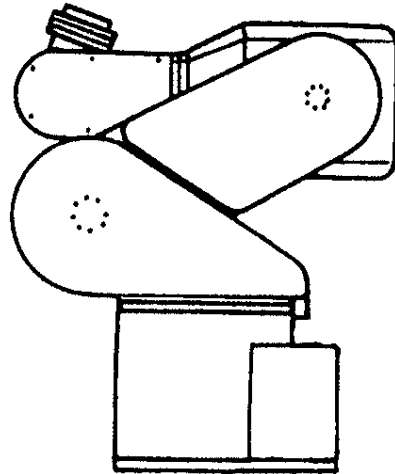

Standard posture

JT1 : 0°

JT2 : -60°

JT3 : -150°

JT4 : 0°

JT5 : +135°

JT6 : 0°



#### CAUTION

**The mass of robot arm is approx. 20 kg for models RS03N(A/B00\*)/  
RA03N(A/B00\*). For your safety, transport robot arm by two or more  
persons.**

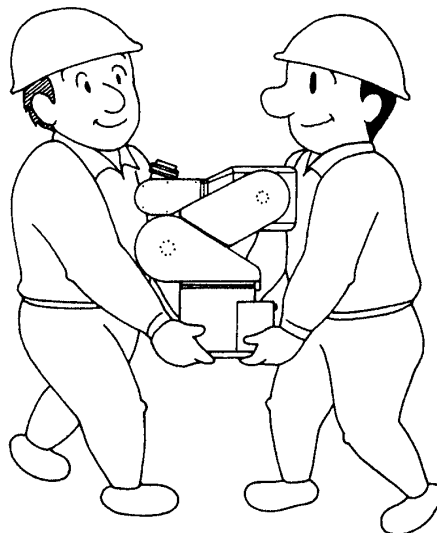

## 4.0 INSTALLATION METHOD

### 4.1 INSTALLING ROBOT ARM

RS03N(A00\*)/RA03N(A00\*)

1. Install robot arm using the  $\phi 9$  bolt holes (4 parts) in the base section as shown below.

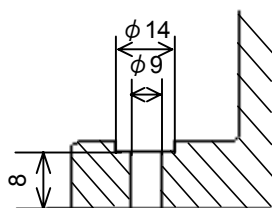
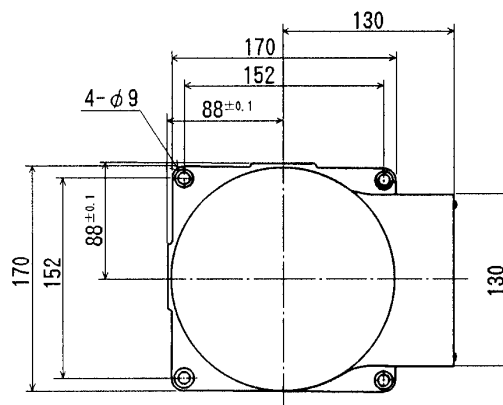
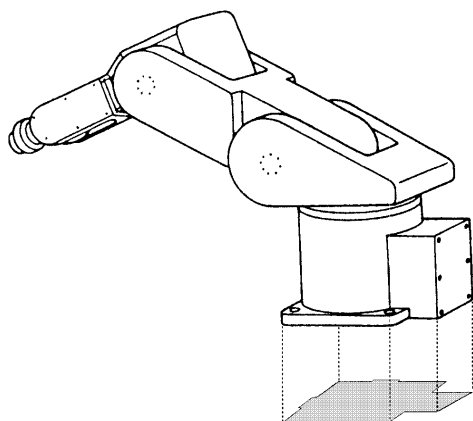

Installation cross-section

High-tension bolt: 4-M8  
Material: SCM435  
Strength level: 10.9 or more  
Tightening torque: 29.40 N·m

2. During operation, the robot arm applies the following moments  $M$  on its installation surface.

At robot installation, confirm this surface can adequately withstand these forces.

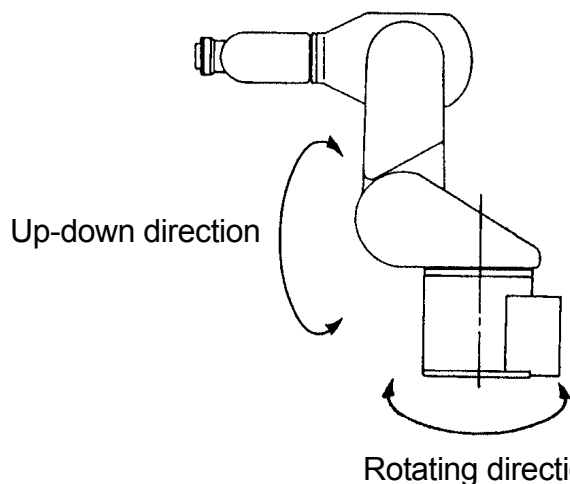

•RS03N(A00\*)/RA03N(A00\*)  
Up-down direction:  $M$  max. = 357 N·m  
Rotating direction:  $M$  max. = 293 N·m

RS03N(B00\*)/RA03N(B00\*)

1. Install robot arm using the  $\phi 9$  bolt holes (4 parts) in the base section as shown below.

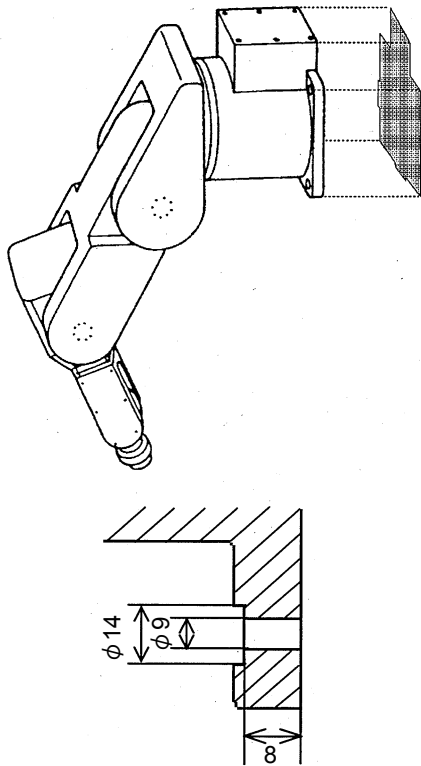

Installation cross-section

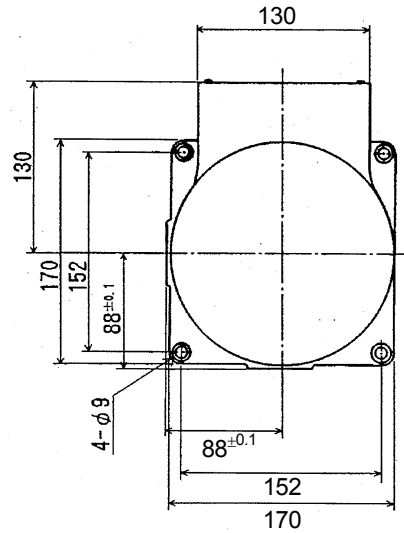

High-tension bolt: 4-M8  
 Material: SCM435  
 Strength level: 10.9 or more  
 Tightening torque: 29.40 N·m

2. During operation, the robot arm applies the following moments  $M$  on its installation surface.  
 At robot installation, confirm this surface can adequately withstand these forces.

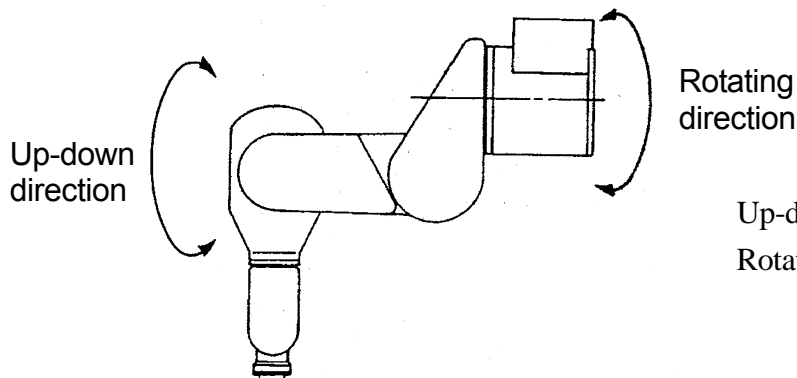

Up-down direction:  $M$  max. = 465 N·m  
 Rotating direction:  $M$  max. = 220 N·m

## 5.0 INSTALLATION OF TOOLS



### WARNING

Prior to installing tools on the robot, turn OFF control power up to the main power source. Display signs indicating clearly “Inspection and Maintenance in Progress”, and lockout/tagout the main power switch to prevent personnel from accidentally turning ON the power.

## 5.1 DIMENSIONS OF WRIST END (FLANGE FACE)

A flange is provided for installation of tool at end of robot arm. Tighten fixing bolts using the four tap holes (M5 bolts) on flange shown below. Also, use the pin holes and spigot hole for positioning tool.

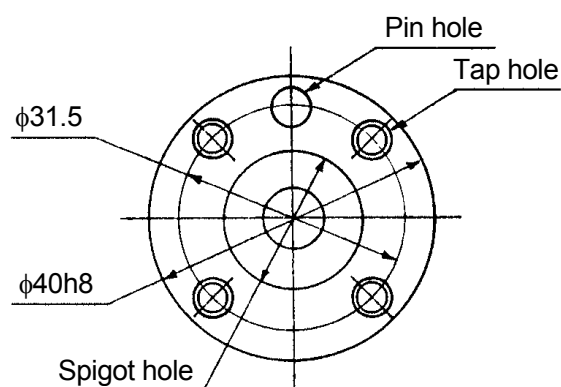

Tap holes: 4-M5, Depth 8 (90° separation)  
Pin hole:  $\phi 5H7$ , Depth 6  
Spigot hole:  $\phi 20H7$ , Depth 4  
Depth of engagement: 6 ~ 8 mm  
High-tension bolt: SCM435,  
Strength level 10.9 or more  
Tightening torque: 6.86 N·m  
(Conforms to ISO9409-1)



### CAUTION

If the depth of engagement (length of fixing bolt within flange) exceeds the specified depth, the fixing bolt may interfere with wrist assembly and the flange cannot rotate.

## 5.2 SETTING THE LOAD MASS

1. The maximum load mass of the robot including the mass of tool, workpiece, etc. is specified per robot model. Also, additional specifications also apply to the max. load torque capacity of the wrist section.
2. Strictly observe the limiting conditions for load torque and load moment of inertia around each wrist axis JT4, JT5, JT6 as shown below.

**⚠ WARNING**

1. **Exceeding the specified load mass may cause deterioration in motion performance and shorten the life of robot.**
2. **The specified load capacity for mass includes the mass of all attachments such as hand, tool changer, shock absorber, etc. When the total load mass exceeds the load capacity specification, be sure to consult Kawasaki before proceeding with operations.**

The load torque and load moment of inertia are evaluated by the following formulae.

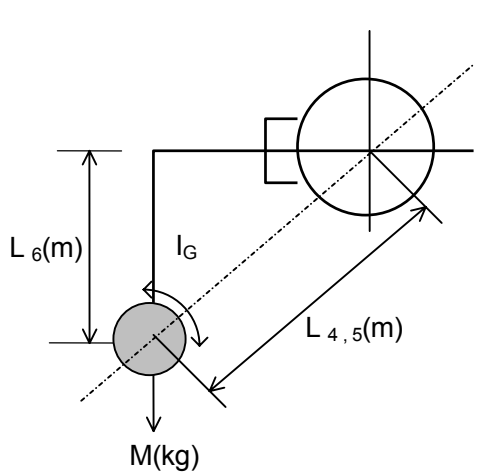

**Formulae**

Load mass (incl. tool):  $M \leq M_{max}$ . (kg)

Load torque:  $T = 9.8 \cdot M \cdot L$  (N·m)

Load moment of inertia:  $I = M \cdot L^2 + I_G$  (kg·m<sup>2</sup>)

$M_{max}$  (RS03N): Maximum load mass=3 kg  
 $M_{max}$  (RA03N): Maximum load mass=3 kg

$I_G$ : Moment of inertia around center of gravity. (kg·m<sup>2</sup>)  
 $L$ : Length from center of rotation axis to load center of gravity. (m)  
 $L_6$ : Length from center of JT6 rotation axis to load center of gravity.  
 $L_{4,5}$ : Length from center of JT4 (JT5) rotation axes to load center of gravity. (See left)

When calculating the load by dividing it into sections (for example, tool section, workpiece section, etc.), evaluate the load torque and load moment of inertia from the sum of all the sections.

Adhere to the following limiting conditions for the load mass, etc. in wrist section.

1. The allowable load mass including the tool mass can be no more than 3 kg.
2. The load torque and the load moment of inertia in each wrist axis (JT4, JT5, JT6) must be within the allowable range shown below.

RS03N (A/B00\*)/ RA03N (A/B00\*)

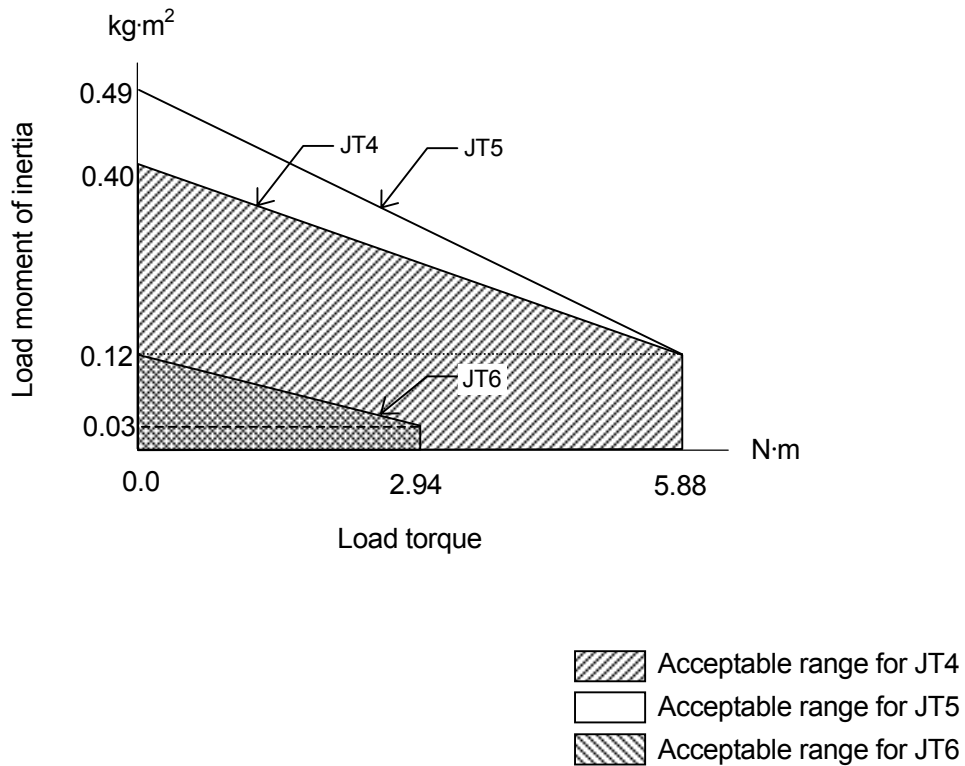

[ NOTE ]

Scales shown in graph are approximate. If load on arm approaches limits, calculate load torque and load moment of inertia exactly.



## 6.0 CONNECTION OF AIR SYSTEM

### 6.1 RS03N (A/B00\*)

#### 6.1.1 AIR PIPING DIAGRAM

For RS03N (A/B00\*), air piping and valves for activating the tool can be installed in the robot arm. The valves can be turned ON/OFF by teach pendant without using an interlock.

Specification of built-in valves is as follows. Standard spec. robot does not house the valves.

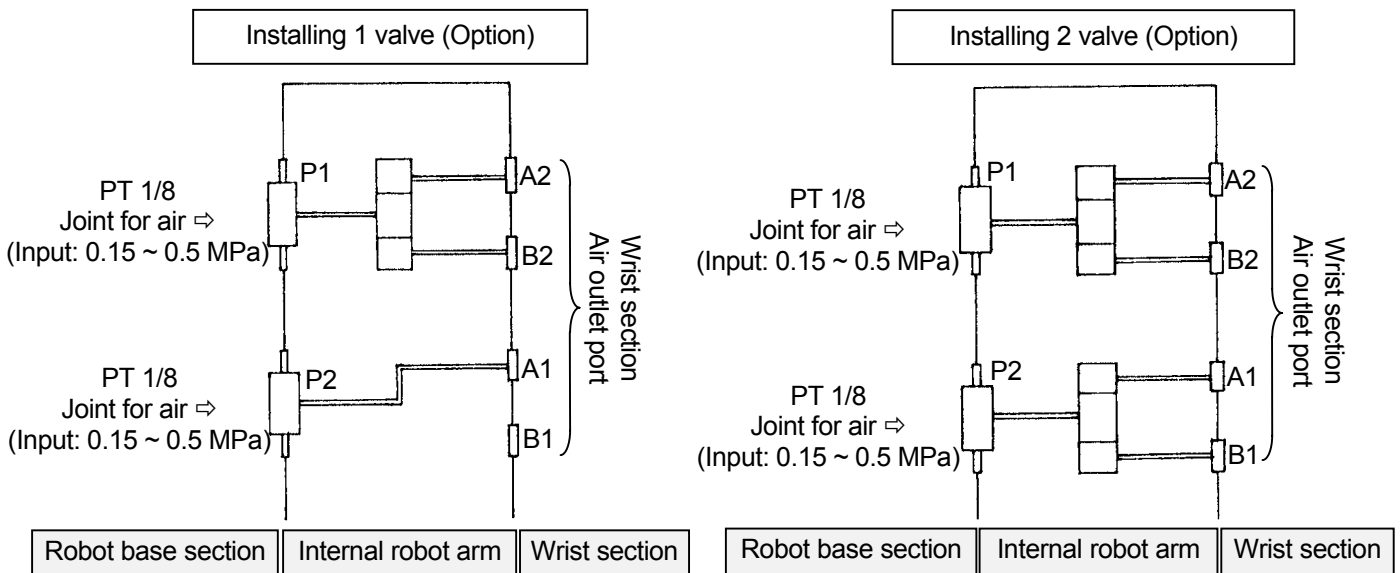
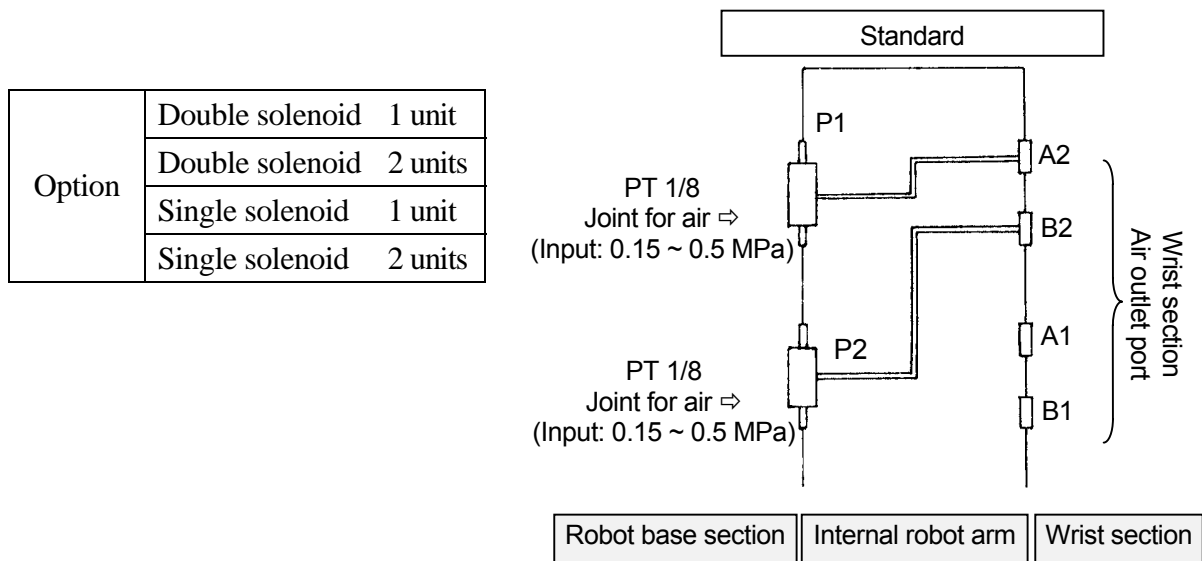

**[ NOTE ]**  
Valve specification: 0.23 CV value, 2 positions. Valves not meeting above specifications can only be installed in arm after consulting Kawasaki for information on air system specifications.

### 6.1.2 CONNECTION TO THE TOOL FROM AIR OUTLET

Air outlet ports are provided in the wrist section as shown in figure below.

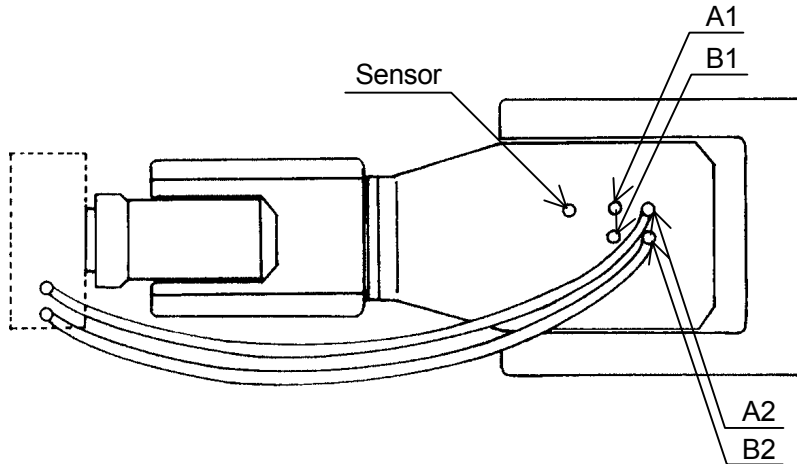

Joint: Universal elbow (SMC:M-5HL-4)

### 6.1.3 AIR INLET TO THE ROBOT ARM

Air connecting ports are provided in the robot base section as shown in figure below.

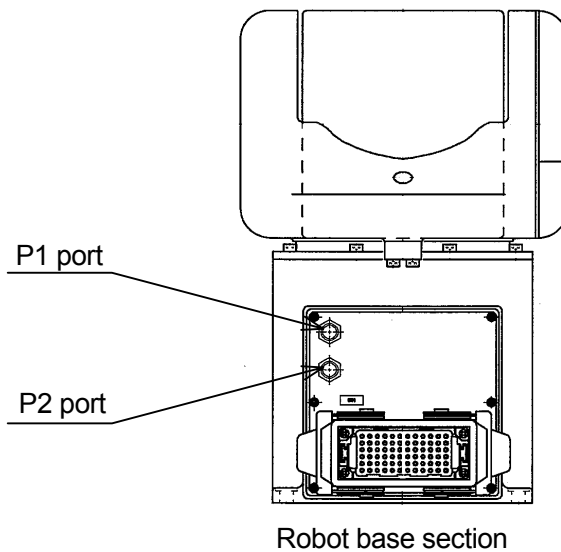

Robot base section

#### ⚠ CAUTION

Air supplied to P1 and P2 ports (PT1/8 joint) for air must be in pressure range: 0.15 ~ 0.5 MPa

#### [ NOTE ]

Refer to 6.1.1 for air piping diagram in the robot arm.

## 7.0 PRECAUTIONS AT REPEAT OPERATION (RS03N/RA03N (A/B00\*))

For (RS03N (A/B00\*)/ RA03N (A/B00\*)), when operating the robot at repeat operation, strictly observe the limiting conditions for motor duty around each wrist axis.

1. JT1 - JT3: 75 % or less
2. JT4 - JT6: 65 % or less

**⚠ CAUTION**

1. **Exceeding the specified load capacity may cause deterioration in motion performance and shorten the life of robot.**
2. **When motor duty exceeds its limit, adjust it to be within the limiting condition by reducing speed or acceleration, teaching a wait time on the motion path, etc.**

[ NOTE ]

Motor duty for each wrist axis can be checked by teach pendant. For more information, refer to the separate option manual “Failure Prediction Function for Reduction Unit”(90210-1188).

Example of motor duty adjustment (For RS03N (A00\*))

Motion pattern	Standard setting (Variable accel/decel ratio: 100 %)	High accel/decel setting (Variable accel/decel ratio: 150 %)
Pick and place continuous motion with load mass of 1 kg. { X-base axis forward/back 10 times (X:300 mm Z:25 mm) Y-base axis forward/back 10 times (Y:300 mm Z:25 mm) Z-base axis forward/back 10 times (Z:300 mm Y:25 mm)	Cycle time: 29 seconds Wait time not required.	Cycle time: 25 seconds Requires 0.9 sec. wait time per 1 sec.-motion.

[ NOTE ]

Percentage settings for acceleration and deceleration can be changed via Aux.0515 Acceleration and deceleration variable function specification.

---

Kawasaki Robot RS03N(A/B00\*), RA03N(A/B00\*)  
Installation and Connection Manual

---

March 2010 : 1st Edition

Published by KAWASAKI HEAVY INDUSTRIES, LTD.

90202-1043DEA

---

All rights reserved. Copyright © 2010 KAWASAKI HEAVY INDUSTRIES, LTD.